

REVISIONS			
REV. NO.	DATE	DESCRIPTION	DWN DES APP

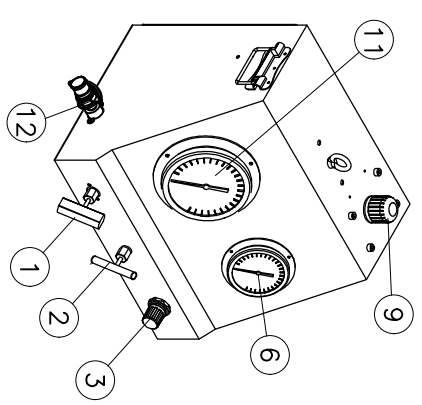
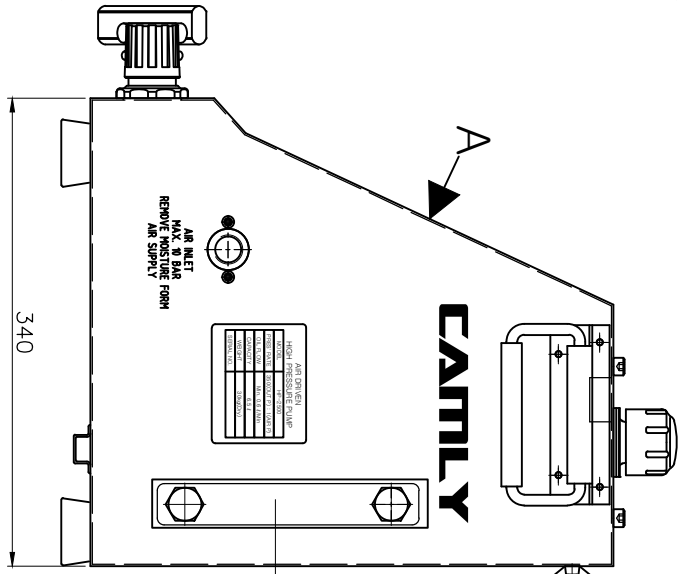
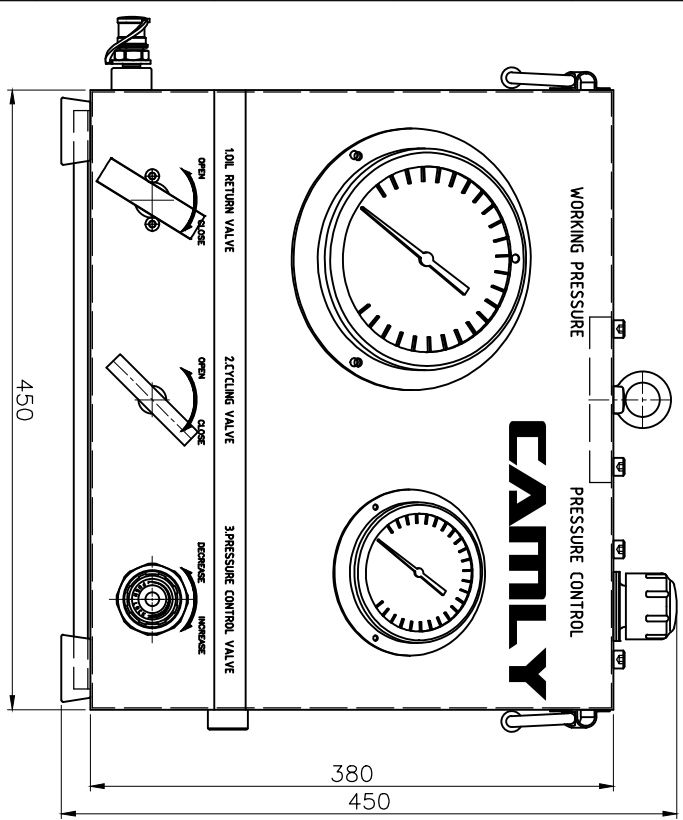

NO	DESCRIPTION	MATERIAL	Qty	SPECIFICATION	CODE	REMARKS
12	H.P. OUTLET PORT		1	10.125.5252		
11	OUTLET GAUGE		1			
9	AIR BREATHER		1	SH-AB-1330		
8	LEVEL GAUGE		1	SH-C-150		
6	AIR GAUGE		1			
3	AIR REGULATOR		1	SAR 3000T-03BG		
2	CYCLING VALVE		1	NV3F-6R		
1	OIL RETURN VALVE		1			

MODEL	CAMLY HP-2500
PRESSURE RATE	350(OUT P) : 1(AIR P)
MAX. PRESSURE	2500 bar
OIL FLOW	Min. 0.6 l/Min
CAPACITY	6.5 l
WEIGHT	30kg(Dry)

DATA	PROJECT	CLIENT
DRAWING TITLE	PROJECT	CLIENT
DESIGNER	ASSEMBLY	
CHECKER	DWG. NO.	FILE NAME
APP. NO.	REF. NO.	SHEET NO.
		1 of 1

CAMLY

A B C D E F G H 1 2 3 4 5 6 7 8

REVISIONS			
REV. NO.	DATE	DESCRIPTION	DWN DES APP

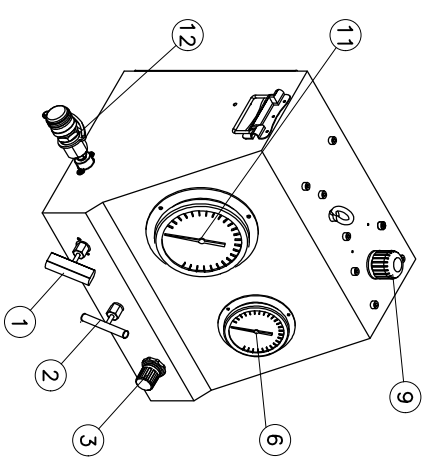
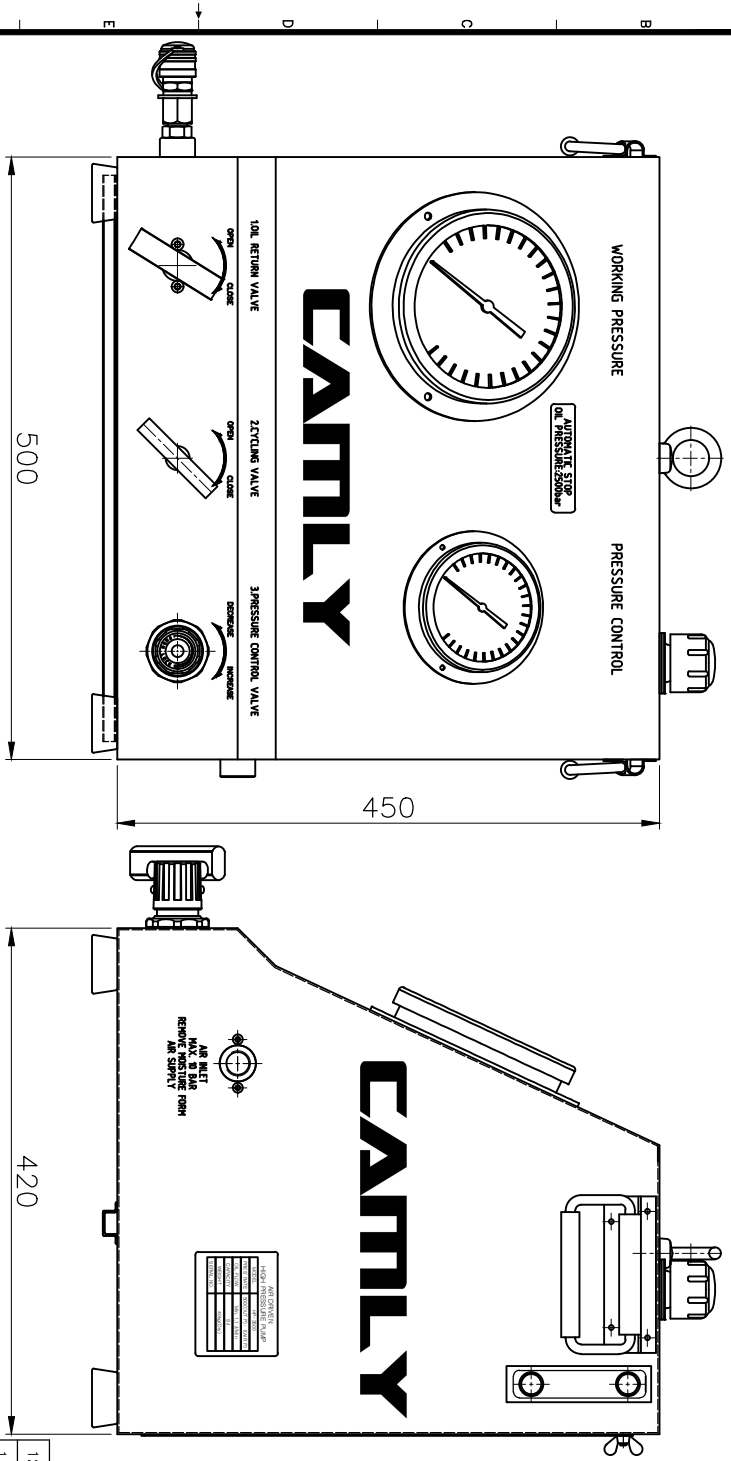

NO	DESCRIPTION	MATERIAL	Qty	SPECIFICATION	CODE	REMARKS
12	H.P. OUTLET PORT		1	10.125.1203		
11	OUTLET GAUGE		1			
9	AIR BREATHER		1	SH-AB-1380		
8	LEVEL GAUGE		1	SH-C-80		
6	AIR GAUGE		1			
3	AIR REGULATOR		1	SAR 3000T-03BG		
2	CYCLING VALVE		1	NV3F-6R		
1	OIL RETURN VALVE		1			

MODEL	{ y t t -HP-3500
PRESSURE RATE	500(OUT P) : 1(AIR P)
MAX. PRESSURE	3500 bar
OIL FLOW	Min. 1.1 l/Min
CAPACITY	8.0 l
WEIGHT	40kg(Drv)

DIM		CLIENT	
mm	NS	SCALE	set
DATA		PROJECT	AIR DRIVEN PUMP(HP-3500)
DRA		TITLE	ASSEMBLY
DES		DWG. NO.	FILE NAME
CHE		REF. NO.	SHEET NO.
APP			1 of 2

CAMILY