

BOLTING APPLICATION DETAILS

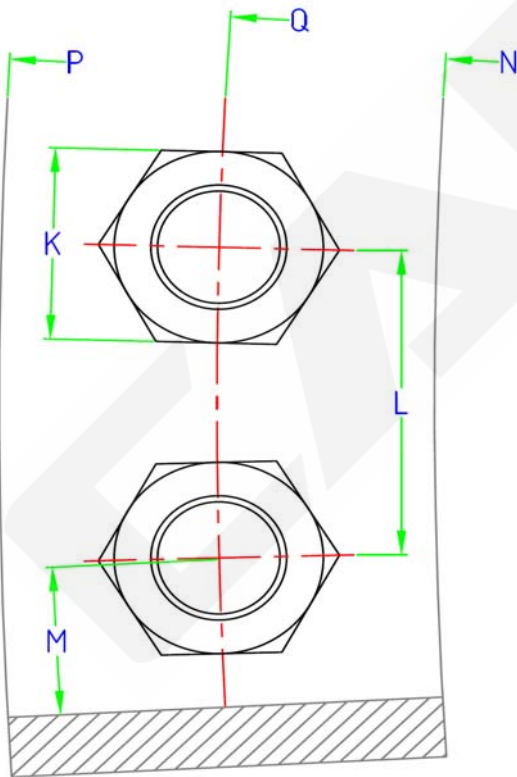
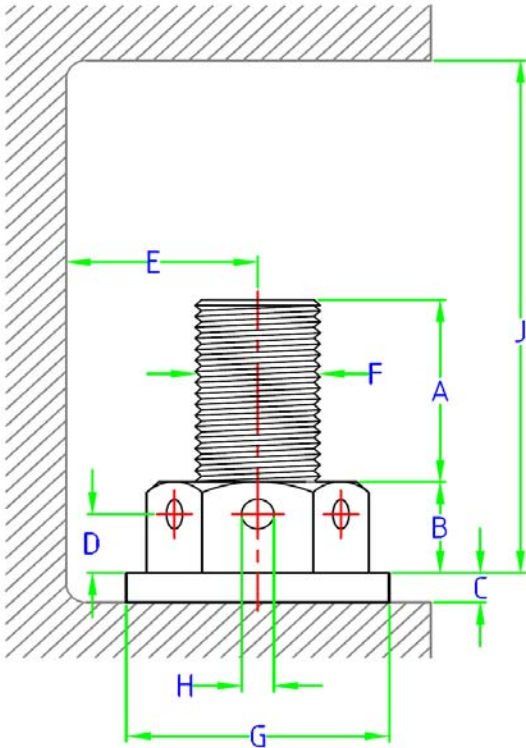

Company : _____

Location : _____

Require Date : _____

A _____ *Protrusion height*

B _____ *Nut height*

C _____ *Washer height*

D _____ *Height of Tommy bar hole*

E _____ *Bolt centre to nearest obstructions*

F _____ *Bolt dia x pitch*

G _____ *Washer dia*

H _____ *Tommy bar hole dia*

J _____ *Nearest overhead obstructions*

K _____ *Across flat hex / Dia round Nut*

L _____ *Bolt centre to centre*

M _____ *Bolt centre to nearest obstructions*

N _____ *ID Dia*

P _____ *OD Dia*

Q _____ *PCD Dia*

Method : _____ *Torque or Tension*

Flange : _____ *Dia x Rating*

Bolt Material : _____ *B7 / B8 / B8M/ B16 / L7/ 8.8 / 10.9 / 12.9*

Lubrication : _____ *Molykote / Machine Oil / Dry*

No. of Bolts : _____ *kN or Tonf*

Bolt Load : _____ *kN or Tonf*

Target Torque : _____ *Nm or ftlbs*

Remarks : _____

CAMLY PTE LTD

A: 5 Soon Lee Street #03-57 Singapore 627607

T : + 65 6503 0553 F : +65 6334 6967

E : sales@camly.sg W : www.camly.sg

